

بِسْمِ اللَّهِ الرَّحْمَنِ الرَّحِيمِ



وزارت علوم، تحقیقات و فناوری  
دانشگاه جیرفت

# سیستمهای دیجیتال ۲

جلسه ۱۱



# ATMEGA16

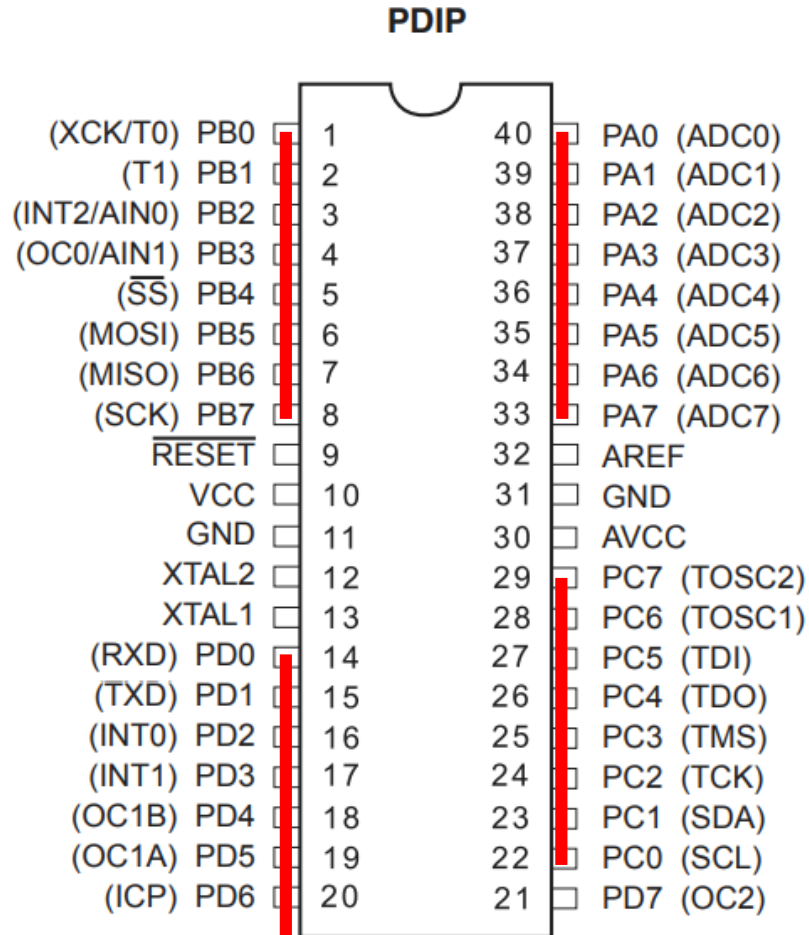
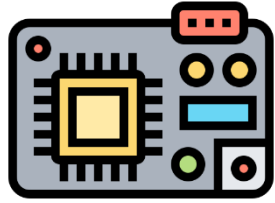

MSB

PB7



• سخت افزار خارجی

• سخت افزار داخلی

• ISA

• یک عدد ۸ بیتی

LSB

PB0



# ساختار ساده شده یک پین

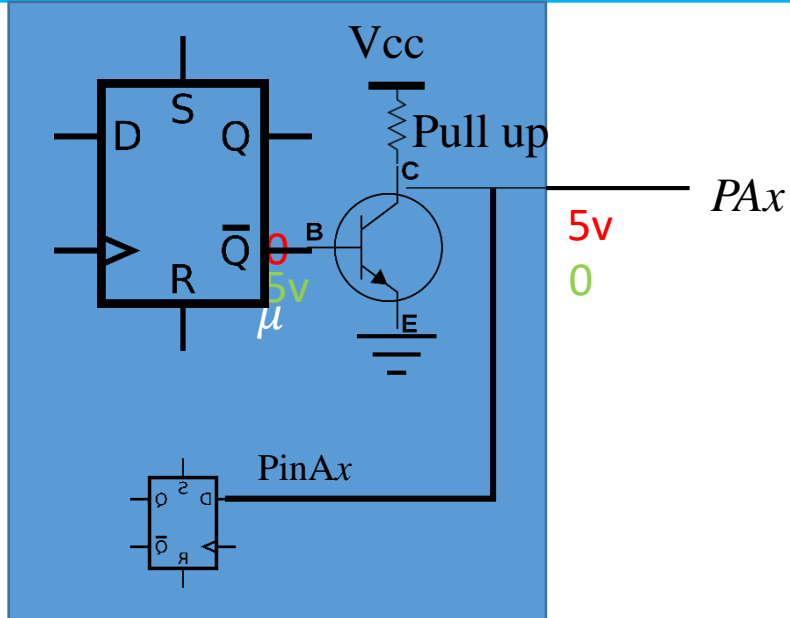
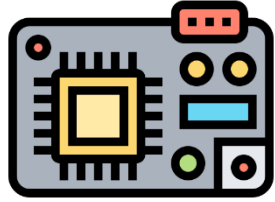

- بررسی عملکرد الکترونیکی پین:
- عملکرد ساده شده:

- هر پورت یکی دارد که مجموعاً رجیستر Port را می‌سازد.
- پایه‌های پورت خوانده هم باید بشود.
- رجیستر Pin برای خواندن است.
- رجیستر DDR هم جهت عملکرد پورت را مشخص می‌کند
- روی هر بیتی ۱ بگذاریم خروجی می‌شود
- اگر صفر بگذاریم ورودی می‌شود.

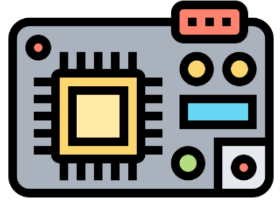

# تبادل اطلاعات از پورت

- برای تفاهم بین صفر و یک مدارها باید ولتاژ صفرشان به هم وصل باشد.
- Common ground

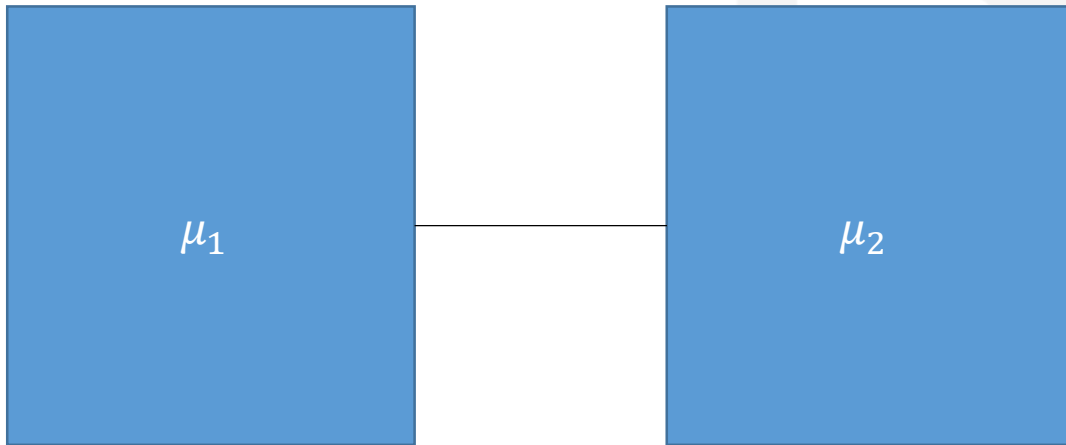

- گیرنده باید پایه خود را صفر کند یا یک؟!
  - اگر صفر کند ترانزیستور وصل است
  - در نتیجه فرستنده هیچوقت نمیتوان آن را یک کند
  - اگر یک بگذارد ترانزیستور قطع است و چون با مقاومت به ۵ وصل است میتواند صفر شود



# پورت‌های میکرو

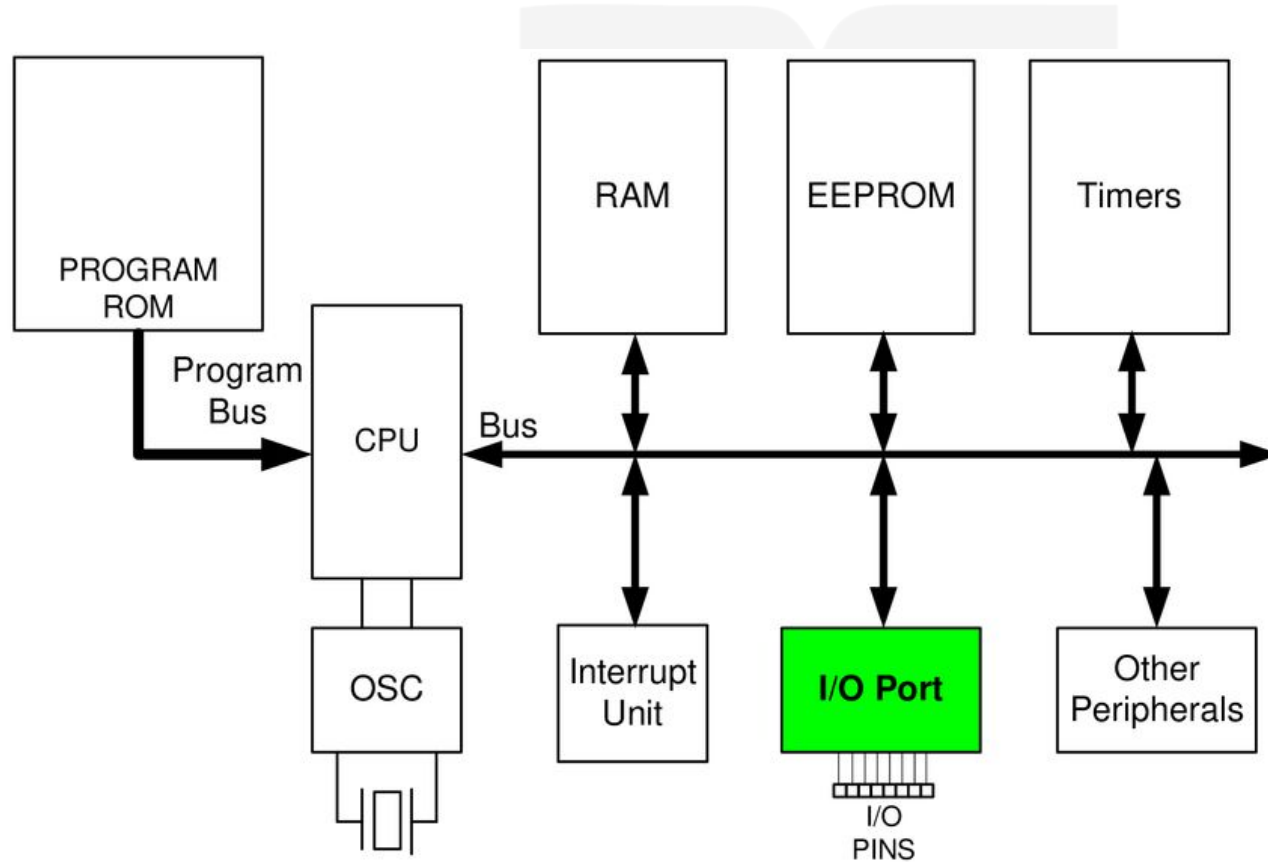
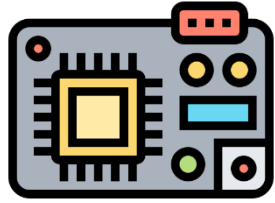



# پورت‌های میکرو

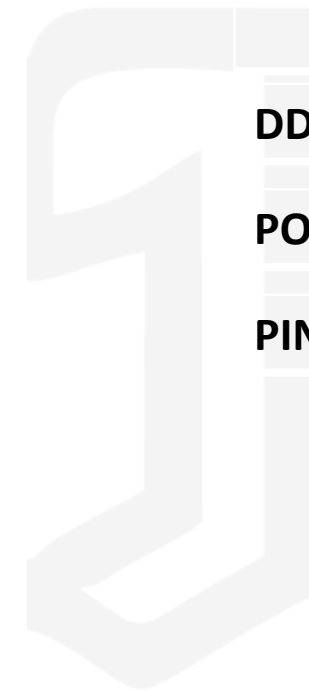
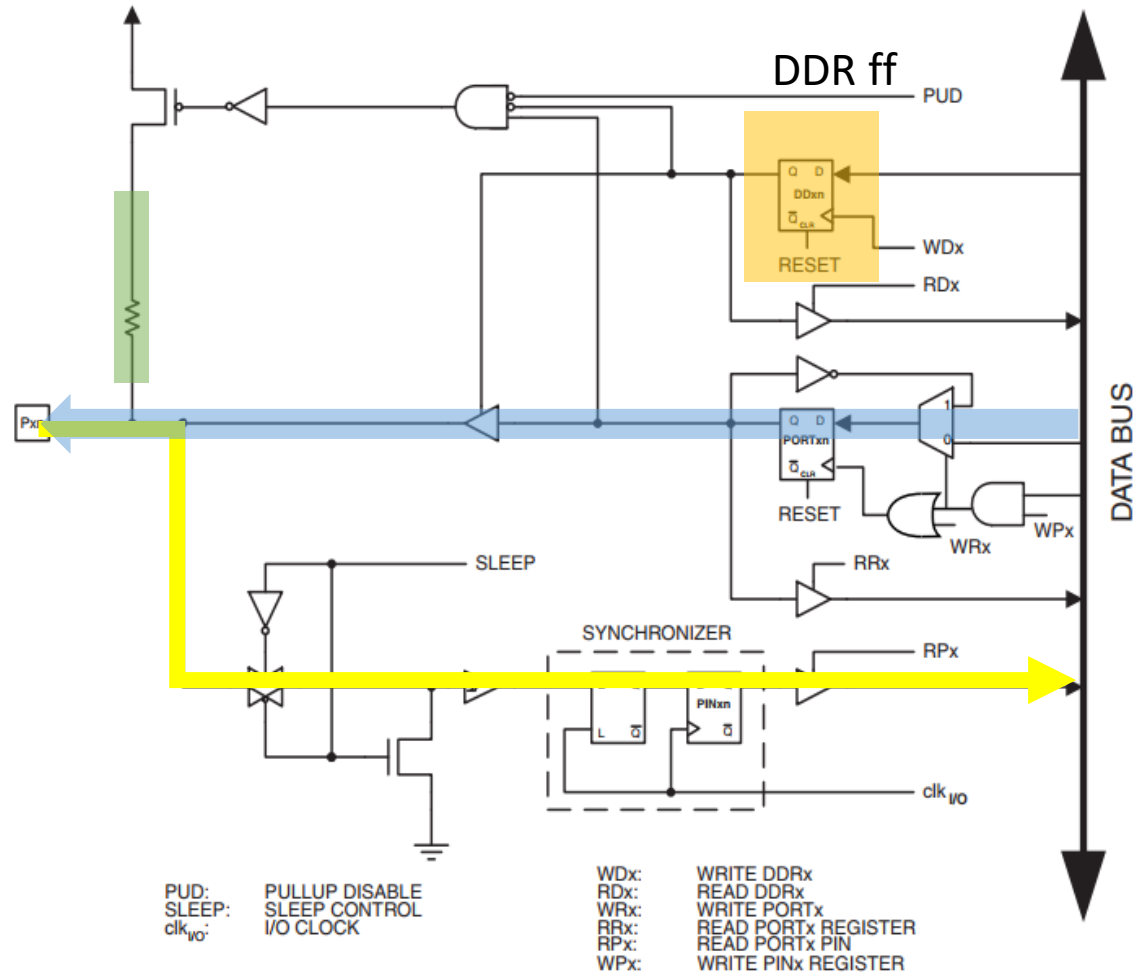
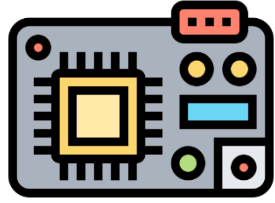

وزارت علوم، تحقیقات و فناوری  
دانشگاه جیرفت

	7	6	5	4	3	2	1	0
DDRA	1	1	1	1	1	0	0	0
PORTA								
PINA								

:DDR  
۱: خروجی  
۲: ورودی



# ATMEGA16

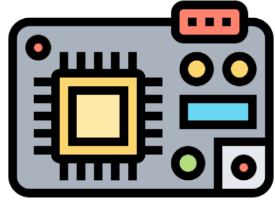
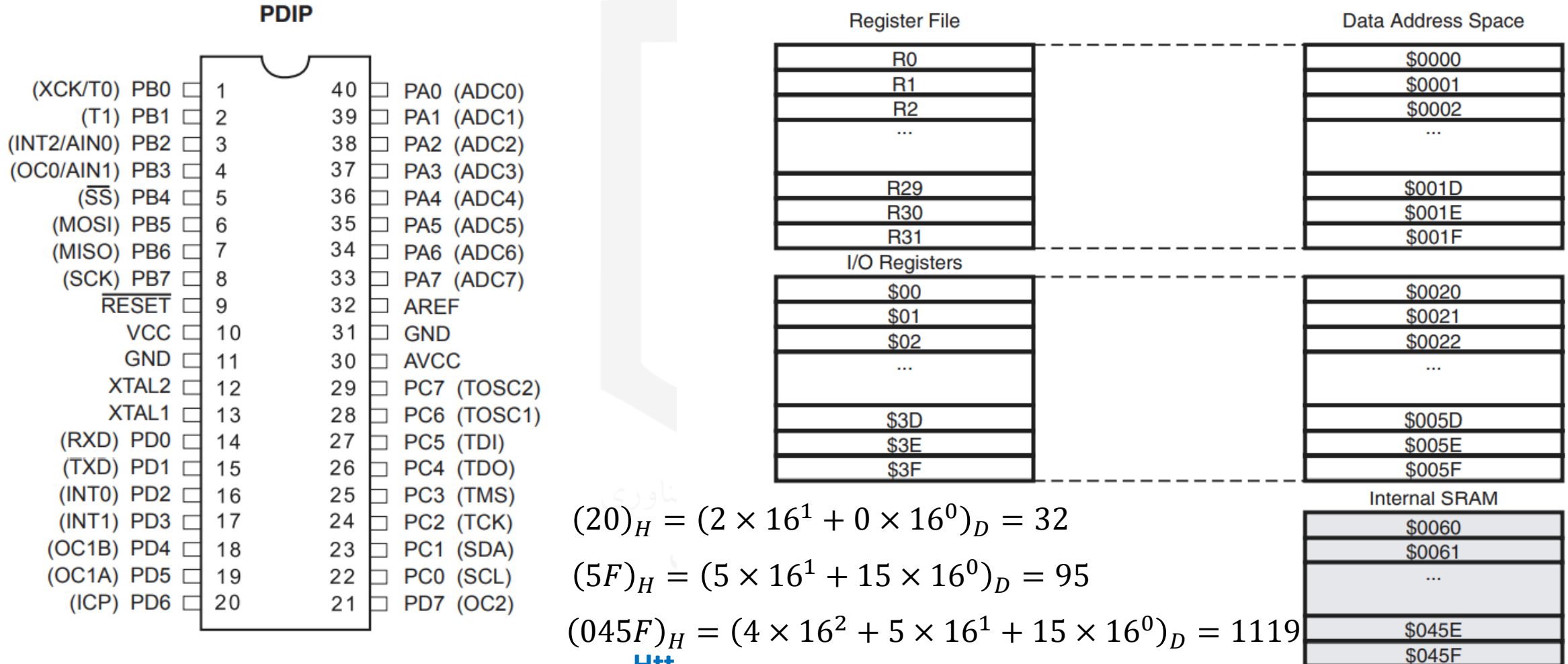
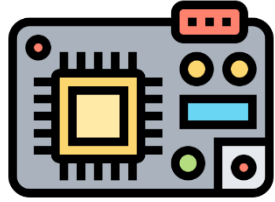

Figure 9. Data Memory Map





# ATMEGA16



General  
Purpose  
Working  
Registers

7	0	Addr.	
	R0	0x00	
	R1	0x01	
	R2	0x02	
	...		
	R13	0x0D	
	R14	0x0E	
	R15	0x0F	
	R16	0x10	X-register Low Byte
	R17	0x11	X-register High Byte
	...		
	R26	0x1A	Y-register Low Byte
	R27	0x1B	Y-register High Byte
	R28	0x1C	Z-register Low Byte
	R29	0x1D	Z-register High Byte
	R30	0x1E	
	R31	0x1F	



# ATMEGA16

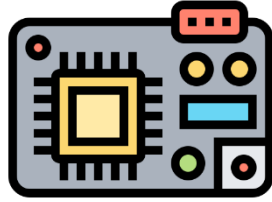

## ATMega32 Programmer Model: I/O Registers (SFRs)

- The I/O memory is dedicated to specific functions such as status register, timers, serial communication, I/O ports, ADC and etc.
- Function of each I/O memory location is fixed by the CPU designer at the time of design. (because it is used for control of the microcontroller and peripherals)
- AVR I/O memory is made of 8 bit registers.
- All of the AVRs have at least 64 bytes of I/O memory location. (This 64 bytes section is called standard I/O memory)
- In other microcontrollers, the I/O registers are called SFRs (Special Function Registers)

Address		Name
I/O	Mem.	
\$00	\$20	TWBR
\$01	\$21	TWASR
\$02	\$22	TWAR
\$03	\$23	TWDR
\$04	\$24	ADCL
\$05	\$25	ADCH
\$06	\$26	ADCSRA
\$07	\$27	ADMUX
\$08	\$28	ACSR
\$09	\$29	UBRRL
\$0A	\$2A	UCSRB
\$0B	\$2B	UCSRA
\$0C	\$2C	UDR
\$0D	\$2D	SPCR
\$0E	\$2E	SPSR
\$0F	\$2F	SPDR
\$10	\$30	IND
\$11	\$31	DDRD
\$12	\$32	PORTD
\$13	\$33	FINC
\$14	\$34	DDRC
\$15	\$35	PORTC

Address		Name
I/O	Mem.	
\$16	\$36	PINB
\$17	\$37	DDRB
\$18	\$38	PORTB
\$19	\$39	PINA
\$1A	\$3A	DDRA
\$1B	\$3B	PORTA
\$1C	\$3C	EEDR
\$1D	\$3D	EEDR
\$1E	\$3E	EEARL
\$1F	\$3F	EEARH
\$20	\$40	UBRRCL
		UBRRH
\$21	\$41	WDTCR
\$22	\$42	ASSR
\$23	\$43	OCR2
\$24	\$44	TCNT2
\$25	\$45	TCR2
\$26	\$46	ICR1L
\$27	\$47	ICR1H
\$28	\$48	OCR1BL
\$29	\$49	OCR1BH
\$2A	\$4A	OCR1AL

Address		Name
I/O	Mem.	
\$2B	\$4B	OCR1AH
\$2C	\$4C	TCNT1L
\$2D	\$4D	TCNT1H
\$2E	\$4E	TCR1B
\$2F	\$4F	TCR1A
\$30	\$50	SFCSR
\$31	\$51	OCDFR
		OSCCAL
\$32	\$52	TCNT0
\$33	\$53	TCR0
\$34	\$54	MCUCSR
\$35	\$55	MCUCR
\$36	\$56	TWCR
\$37	\$57	SPMCR
\$38	\$58	TIFR
\$39	\$59	TIMSK
\$3A	\$5A	GIFR
\$3B	\$5B	GICR
\$3C	\$5C	OCR0
\$3D	\$5D	SPL
\$3E	\$5E	SFH
\$3E	\$5E	SREG





# ATMEGA16

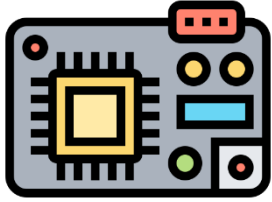

## Register Summary

Address	Name	Bit 7	Bit 6	Bit 5	Bit 4	Bit 3	Bit 2	Bit 1	Bit 0	Page
\$3F (\$5F)	SREG	I	T	H	S	V	N	Z	C	7
\$3E (\$5E)	SPH	–	–	–	–	–	SP10	SP9	SP8	10
\$3D (\$5D)	SPL	SP7	SP6	SP5	SP4	SP3	SP2	SP1	SP0	10
\$3C (\$5C)	OCR0	Timer/Counter0 Output Compare Register								80
\$3B (\$5B)	GICR	INT1	INT0	INT2	–	–	–	IVSEL	IVCE	45, 65
\$3A (\$5A)	GIFR	INTF1	INTF0	INTF2	–	–	–	–	–	66
\$39 (\$59)	TIMSK	OCIE2	TOIE2	TICIE1	OCIE1A	OCIE1B	TOIE1	OCIE0	TOIE0	80, 109, 126
\$38 (\$58)	TIFR	OCF2	TOV2	ICF1	OCF1A	OCF1B	TOV1	OCF0	TOV0	80, 110, 127
\$37 (\$57)	SPMCR	SPMIE	RWWSB	–	RWWSRE	BLBSET	PGWRT	PGERS	SPMEN	245
\$36 (\$56)	TWCR	TWINT	TWEA	TWSTA	TWSTO	TWWC	TWEN	–	TWIE	174
\$35 (\$55)	MCUCR	SM2	SE	SM1	SM0	ISC11	ISC10	ISC01	ISC00	30, 64
\$34 (\$54)	MCUCSR	JTD	ISC2	–	JTRF	WDRF	BORF	EXTRF	PORF	38, 65, 225
\$33 (\$53)	TCCR0	FOC0	WGM00	COM01	COM00	WGM01	CS02	CS01	CS00	77
\$32 (\$52)	TCNT0	Timer/Counter0 (8 Bits)								79
\$31 <sup>(1)</sup> (\$51) <sup>(1)</sup>	OSCCAL	Oscillator Calibration Register								28
	OCDR	On-Chip Debug Register								221
\$30 (\$50)	SFIOR	ADTS2	ADTS1	ADTS0	ADHSM	ACME	PUD	PSR2	PSR10	54,82,128,195,215
\$2F (\$4F)	TCCR1A	COM1A1	COM1A0	COM1B1	COM1B0	FOC1A	FOC1B	WGM11	WGM10	104
\$2E (\$4E)	TCCR1B	ICNC1	ICES1	–	WGM13	WGM12	CS12	CS11	CS10	107
\$2D (\$4D)	TCNT1H	Timer/Counter1 – Counter Register High Byte								108
\$2C (\$4C)	TCNT1L	Timer/Counter1 – Counter Register Low Byte								108
\$2B (\$4B)	OCR1AH	Timer/Counter1 – Output Compare Register A High Byte								108
\$2A (\$4A)	OCR1AL	Timer/Counter1 – Output Compare Register A Low Byte								108
\$29 (\$49)	OCR1BH	Timer/Counter1 – Output Compare Register B High Byte								108
\$28 (\$48)	OCR1BL	Timer/Counter1 – Output Compare Register B Low Byte								108
\$27 (\$47)	ICR1H	Timer/Counter1 – Input Capture Register High Byte								109
\$26 (\$46)	ICR1L	Timer/Counter1 – Input Capture Register Low Byte								109
\$25 (\$45)	TCCR2	FOC2	WGM20	COM21	COM20	WGM21	CS22	CS21	CS20	121
\$24 (\$44)	TCNT2	Timer/Counter2 (8 Bits)								122



# ATMEGA16

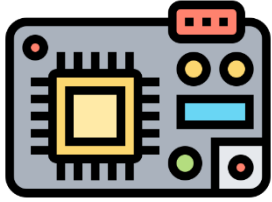

\$25 (\$45)	TCCR2	FOC2	WGM20	COM21	COM20	WGM21	CS22	CS21	CS20	121
\$24 (\$44)	TCNT2	Timer/Counter2 (8 Bits)								123
\$23 (\$43)	OCR2	Timer/Counter2 Output Compare Register								124
\$22 (\$42)	ASSR	-	-	-	-	AS2	TCN2UB	OCR2UB	TCR2UB	124
\$21 (\$41)	WDTCSR	-	-	-	WDTOE	WDE	WDP2	WDP1	WDP0	40
\$20 <sup>(2)</sup> (\$40) <sup>(2)</sup>	UBRRH	URSEL	-	-	-	UBRR[11:8]				161
	UCSRC	URSEL	UMSEL	UPM1	UPM0	USBS	UCSZ1	UCSZ0	UCPOL	159
\$1F (\$3F)	EEARH	-	-	-	-	-	-	-	EEAR8	17
\$1E (\$3E)	EEARL	EEPROM Address Register Low Byte								17
\$1D (\$3D)	EEDR	EEPROM Data Register								17
\$1C (\$3C)	<b>EEDR</b>	-	-	-	-	EERIE	EEMWE	EEWE	EERE	17
\$1B (\$3B)	PORTA	PORTA7	PORTA6	PORTA5	PORTA4	PORTA3	PORTA2	PORTA1	PORTA0	62
\$1A (\$3A)	DDRA	DDA7	DDA6	DDA5	DDA4	DDA3	DDA2	DDA1	DDA0	62
\$19 (\$39)	PINA	PINA7	PINA6	PINA5	PINA4	PINA3	PINA2	PINA1	PINA0	62
\$18 (\$38)	PORTB	PORTB7	PORTB6	PORTB5	PORTB4	PORTB3	PORTB2	PORTB1	PORTB0	62
\$17 (\$37)	DDRB	DDB7	DDB6	DDB5	DDB4	DDB3	DDB2	DDB1	DDB0	62
\$16 (\$36)	PINB	PINB7	PINB6	PINB5	PINB4	PINB3	PINB2	PINB1	PINB0	63
\$15 (\$35)	PORTC	PORTC7	PORTC6	PORTC5	PORTC4	PORTC3	PORTC2	PORTC1	PORTC0	63
\$14 (\$34)	DDRC	DDC7	DDC6	DDC5	DDC4	DDC3	DDC2	DDC1	DDC0	63
\$13 (\$33)	PINC	PINC7	PINC6	PINC5	PINC4	PINC3	PINC2	PINC1	PINC0	63
\$12 (\$32)	PORTD	PORTD7	PORTD6	PORTD5	PORTD4	PORTD3	PORTD2	PORTD1	PORTD0	63
\$11 (\$31)	DDRD	DDD7	DDD6	DDD5	DDD4	DDD3	DDD2	DDD1	DDD0	63
\$10 (\$30)	PIND	PIND7	PIND6	PIND5	PIND4	PIND3	PIND2	PIND1	PIND0	63
\$0F (\$2F)	SPDR	SPI Data Register								135
\$0E (\$2E)	SPSR	SPIF	WCOL	-	-	-	-	-	SPI2X	134
\$0D (\$2D)	SPCR	SPIE	SPE	DORD	MSTR	CPOL	CPHA	SPR1	SPR0	133
\$0C (\$2C)	UDR	USART I/O Data Register								156
\$0B (\$2B)	UCSRA	RXC	TXC	UDRE	FE	DOR	PE	U2X	MPCM	157
\$0A (\$2A)	UCSRB	RXCIE	TXCIE	UDRIE	RXEN	TXEN	UCSZ2	RXB8	TXB8	158
\$09 (\$29)	UBRRH	USART Baud Rate Register Low Byte								161
\$08 (\$28)	ACSR	ACD	ACBG	ACO	ACI	ACIE	ACIC	ACIS1	ACIS0	195
\$07 (\$27)	ADMUX	REFS1	REFS0	ADLAR	MUX4	MUX3	MUX2	MUX1	MUX0	211
\$06 (\$26)	ADCSRA	ADEN	ADSC	ADATE	ADIF	ADIE	ADPS2	ADPS1	ADPS0	213
\$05 (\$25)	ADCH	ADC Data Register High Byte								214
\$04 (\$24)	ADCL	ADC Data Register Low Byte								214
\$03 (\$23)	TWDR	Two-wire Serial Interface Data Register								176
\$02 (\$22)	TWAR	TWA6	TWA5	TWA4	TWA3	TWA2	TWA1	TWA0	TWGCE	176

p298 •



# ATMEGA16

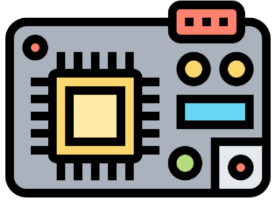

• حافظه برنامه

